

MKC-300HD

Digital Process Compact 3CMOS Color Camera

Operation Manual

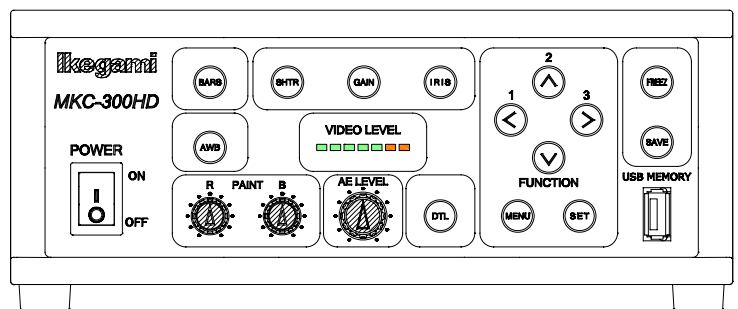
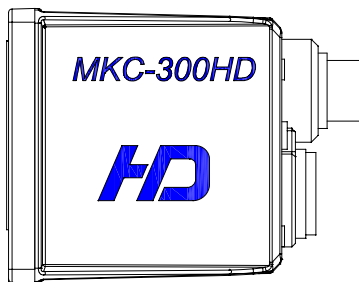

Ikegami

The copyright of the software made for this product
is in Ikegami Tsushinki Co., Ltd.
It forbids to reproduction, a change, and so on about

Safety Precautions

For safe and correct usage



Thoroughly read the “Safety Precautions” and the operation manual before using the unit. Keep them carefully after reading and use as ready reference.

Pictorial Symbols

The “Safety Precautions” and markings on the product contain various pictorial symbols to assure the safety use of the product and prevent an injury to you and other persons as well as property damage.



As each symbol has the following meanings, thoroughly understand them before using the unit.

Please note that some precautions may not be applicable to the product that you purchased.

	WARNING: Indicates a potentially hazardous situation that may arise due to improper handling by taking no notice of this symbol and could result in a serious injury or death.
	CAUTION: Indicates a potentially hazardous situation that may arise due to improper handling by taking no notice of this symbol and could result in an injury or property damage only.





[Note] △ means a heads-up.

Examples of symbols



	Symbol “⊘” means a prohibited action. The content of prohibited matter is mentioned near or in the figure. (The figure on the left side represents “Caution for disassembling”.)
	Symbol “Ⓢ” means a mandatory or directive content. Practical precautions are shown in the figure. (The figure on the left side represents “Pull out power plug from plug outlet.”)

The copyright of the software made for this product is in Ikegami Tsushinki Co., Ltd. It forbids to reproduction, a change, and so on about a part of this calligraphy or all without









1. . 1 CAUTION When using the unit:

	Do not place a receptacle containing water or a small metallic piece on the unit! If water spills in the unit, a fire or electric shock may be caused.
	Do not use other power supply voltage than specified! A fire or electric shock may be caused.
	Do not put a metal body or flammable material into the opening of the unit! Do not drop in such material! A fire or electric shock may be caused.
	Do not make alterations to the unit! A fire or electric shock may be caused.





When installing the unit:

	Do not set the unit in an unstable place! It may drop or turn down, causing an injury.
	Do not connect to any other equipment than specified! A fire or electric shock may be caused.
	When fixing the unit, ask a professional contractor! When fixing the unit, do so in accordance with the specified procedure; otherwise it may drop or turn down, causing a fire, electric shock or injury. Especially when fixing it to the wall or ceiling, be sure to ask a professional contractor.

When an abnormal state occurs:

 	If the unit produces smoke, gives out a foul smell or produces an abnormal sound, turn off the power switch immediately and pull out the power plug! If the unit is used as it is, a fire or electric shock may be caused. Check that no smoke is produced, and then contact the dealer or sales representative.
 	If water or foreign matter enters the unit, turn off the power switch and pull out the power plug! If the unit is used as it is, a fire or electric shock may be caused. Check that no smoke is produced, and then contact the dealer or sales representative.
 	If the unit is dropped or the case is broken, turn off the power switch and pull out the power plug! If the unit is used as it is, a fire or electric shock may be caused. Contact the dealer or sales representative.
 	If the unit fails to operate properly, turn off the power switch and pull out the power plug! If the unit is used as it is, a fire or electric shock may be caused. Contact the dealer or sales representative.
	Do not use any damaged power cord (exposed core, broken wire, etc.)! If the unit is used as it is, a fire or electric shock may be caused. Contact the dealer or sales representative.

WARNING:**When installing the unit:**

	Do not place a heavy thing on the unit! The unit may lose a balance or drop, causing an injury.
	Do not get a leg over the unit or carrying case! Do not sit down on it! The unit may break down or turn down, causing an injury.
	When moving the unit, be sure to turn off the power switch, pull out the power plug and remove the connecting cable between the unit and equipment beforehand. The cord may be damaged, causing a fire or electric shock.
	When the unit is not used for a long period of time, be sure to pull out the power plug for safety's sake. Otherwise, it may cause a fire.

When installing the unit:

	Do not block up the ventilating hole of the unit! If the ventilating hole of the unit is blocked up, heat will accumulate internally, causing a fire. Avoid the following usage: <ul style="list-style-type: none"> • Turning up or down the unit. Turning it sideways. • Pushing it in ill-ventilated place. • Placing it on a carpet etc. • Covering it with a table cloth etc.
---	--

Hints on proper usage**When using the unit:**

<ul style="list-style-type: none"> • When using the unit in a water-place such as bathroom, poolside, etc., prevent water from flowing into the unit and cable; otherwise causing an electric shock. When using it in rainy weather, during snowing, on the seaside or waterside, and in a cooking place, use care to prevent such an accident.
<ul style="list-style-type: none"> • When snow comes on, check the surrounding conditions before use. Stop using the unit temporarily as necessary and do not touch it; otherwise causing an electric shock.
<ul style="list-style-type: none"> • Do not connect any equipment whose required electric power exceeds the wattage (W) that can be supplied from the AC outlet. Refer to wattage shown near the AC outlet or in the operation manual.
<ul style="list-style-type: none"> • Do not bend (or twist or pull) the power cord and connecting cable excessively. The covering material of the cord and cable may break, causing an electric shock.

When installing the unit:

Avoid installing the unit in a moist place, dusty place or any other place exposed to oily smoke and vapor; otherwise causing an electric shock. Do not place the unit near a cooking table or humidifier.
<ul style="list-style-type: none"> • As this unit is heavy (over 10Kg), carry it by 2 or more persons. If it is carried by one person, it may turn down or drop, some- times causing an physical damage to the waist or hand or a physical injury.
<ul style="list-style-type: none"> • Take preventive measures against the overturn of the unit due to an earthquake or sudden shock. As the unit may overturn and cause a physical injury, take preventive measures against the overturn.

Maintenance

Turn off the power switch and pull out the power plug before maintenance; otherwise, causing an electric shock.
In order to keep a long and stable performance, "Periodical check" is recommended. For details of the periodical check, consult with the sales representative.
As the unit has high-voltage parts in it, an expert who has the knowledge about the product should perform these check, maintenance and repair; otherwise causing an electric shock.
Wipe the dirt/dust off the camera using a dry, soft cloth. If the stain is stubborn soak the cloth with water or detergent, wring well and wipe. If you use detergent, wipe off the detergent with a cloth that was soaked in just water and wring well. When wiping, always turn the power off, and take care not to spill water in the camera.

The MKC-300HD is authorized UL60601 Class I .

NOTE: This equipment has been tested and found to comply with the limits for a Class A digital device, pursuant to part 15 of the FCC Rules. These limits are designed to provide reasonable protection against harmful interference when the equipment is operated in a commercial environment. This equipment generates, uses, and can radiate radio frequency energy and, if not installed and used in accordance with the instruction manual, may cause harmful interference to radio communication. Operation of this equipment in a residential area is likely to cause harmful interference in which case the user will be required to correct the interference at his own expense.

Changes or modifications not expressly approved by the party responsible for compliance could void the user's authority to operate the equipment.

Please classify by the material, and dispose of them according to the law and the ordinance etc. of the country and the local government when you dispose of the main body and materials for packing.

The MKC-300HD is not AP·APG equipment.

The BATTERY for BT1 in MKC-300HD, that should be used same model as below when you need to exchange it.
MODEL : CR2032

Guidance and manufacturer's declaration - electromagnetic emissions		
The Model MKC-300HD is intended for use in the electromagnetic environment specified below. The customer or the user of the Model MKC-300HD should assure that it is used in such an environment.		
Emissions test	Compliance	Electromagnetic
RF emissions CISPR 11	Group 1	The Model MKC-300HD uses RF energy only for its internal function. Therefore, its RF emissions are very low and are not likely to cause any interference in nearby electronic equipment.
RF emissions CISPR 11	Class A	The Model MKC-300HD is suitable for use in all establishments other than domestic and those directly connected to the public low-voltage power supply network that supplies buildings used for domestic purposes.
Harmonic emissions IEC61000-3-2	Class A	
Voltage fluctuations/flicker emissions IEC61000-3-3	Complies	

Immunity test	IEC 60601 test level	compliance level	Electromagnetic environment guidance
Electrostatic discharge(ESD) IEC61000-4-2	±6kV contact ±8kV air	±6kV contact ±8kV air	Floors should be wood, concrete or ceramic tile. If floors are covered with synthetic material, the relative humidity should be at least 30%.
Electrical fast transient/burst IEC61000-4-4	±2kV for power supply lines ±1kV for input/output lines	±2kV for power supply lines ±1kV for input/output lines	Main power quality should be that of a typical commercial or hospital environment.
Surge IEC61000-4-5	±1kV differential mode ±2kV common mode	±1kV differential mode ±2kV common mode	Main power quality should be that of a typical commercial or hospital environment
Voltage dips, short interruptions and voltage variations on power supply input lines. IEC61000-4-11	<5% Ut (>95% dip In Ut) for 0.5 cycle 40% Ut (60% dip In Ut) for 5 cycle 70% Ut (30% dip In Ut) for 25 cycle <5% Ut (>95% dip In Ut) for 5 cycle	<5% Ut (>95% dip In Ut) for 0.5 cycle 40% Ut (60% dip In Ut) for 5 cycle 70% Ut (30% dip In Ut) for 25 cycle <5% Ut (>95% dip In Ut) for 5 cycle	Main power quality should be that of a typical commercial or hospital environment. If the user of the MODEL MKC-300HD requires continued operation during power mains interruptions, It is recommended that the MODEL MKC-300HD be powered from an uninterruptible power supply or battery.
Power frequency (50/60 Hz) magnetic field IEC61000-4-8	3 A/m	3 A/m	Power frequency magnetic fields should be at characteristic of a typical location In a typical commercial or hospital environment.
NOTE Ut is the a.c.mains voltage prior to application of the test level.			

Guidance and manufacturer's declaration - electromagnetic emissions			
The Model MKC-300HD is intended for use in the electromagnetic environment specified below. The customer or the user of the Model MKC-300HD should assure that it is used in such an environment.			
Immunity test	IEC 60601 test level	compliance level	Electromagnetic environment guidance
Conducted RF IEC61000-4-6	3 Vrms 150 kHz to 80 MHz	3 Vrms	Portable and mobile RF communications should be used no closer to any part of the MODEL MKC-300HD, including cables, than the recommended separation distance calculated from the equation applicable to the frequency of the transmitter. Recommended separation distance $d=1.2\sqrt{P}$ $d=1.2\sqrt{P}$ 80~800 MHz $d=1.2\sqrt{P}$ 800 MHz~2.5 GHz where P is the maximum output power rating of the transmitter in watts (W) according to the transmitter manufacturer and d is the recommended separation distance in meters(m) Field strengths from fixed RF transmitters, as determined by an electromagnetic site survey, ^a should be less than the compliance level in each frequency range ^{*b} . Interference may occur in the vicinity of equipment marked with the following symbol:
Radiated RF IEC61000-4-3	3 V/m 80 MHz to 2.5 GHz	3 V/m	
NOTE 1 At 80 MHz and 800 MHz, the higher frequency range apply. NOTE 2 These guidelines may not apply in all situations. Electromagnetic propagation is affected by absorption and reflection from structures, objects and people.			
^a Field strengths from fixed transmitters, such as base stations for radio (cellular/cordless) telephones and land mobile radios, amateur radio, AM and FM radio broadcast and TV broadcast cannot be predicted theoretically with accuracy. To assess the electromagnetic environment due to fixed RF transmitters, an electromagnetic site survey should be considered. If the measured field strength in the location in which the MODEL MKC-300HD is used exceeds the applicable RF compliance level above, the MODEL MKC-300HD should be observed to verify normal operation. If abnormal performance is observed, additional measures may be necessary, such as reorienting or relocating the MODEL MKC-300HD. ^{*b} Over the frequency range 150 kHz to 80 MHz, field strengths should be less than 3 V/m.			

CONTENTS

2.	Name and Function of Each Parts	6
■	Camera Head.....	6
■	Front Panel of Camera Control Unit (CCU)	5
■	Rear Panel of Camera Control Unit (CCU).....	9
3.	Operation	11
■	Connection	11
■	Electrical Connection	12
■	Setting Auto White Balance.....	13
4.	Menu Operation	14
■	Operation Method	14
■	Video Adjust.....	15
■	AE Mode	16
■	DTL Set.....	17
■	Video Setting	18
■	Auto Adjust	19
■	Scene File.....	20
■	Foot Switch Mode	21
■	Inverse	22
■	STILL Setting.....	22
■	Date/Time Adjust.....	23
■	DVI Setting	23
■	Down Converter setting	24
■	Miscellaneous	24
■	Version Info.....	25
5.	Specification	25
■	Ratings.....	25
■	Performance.....	26
■	Functions	26
6.	External Appearance.....	28
■	Camera Head Unit: mm.....	28
■	CCU.....	28

2. Name and Function of Each Parts

■ Camera Head

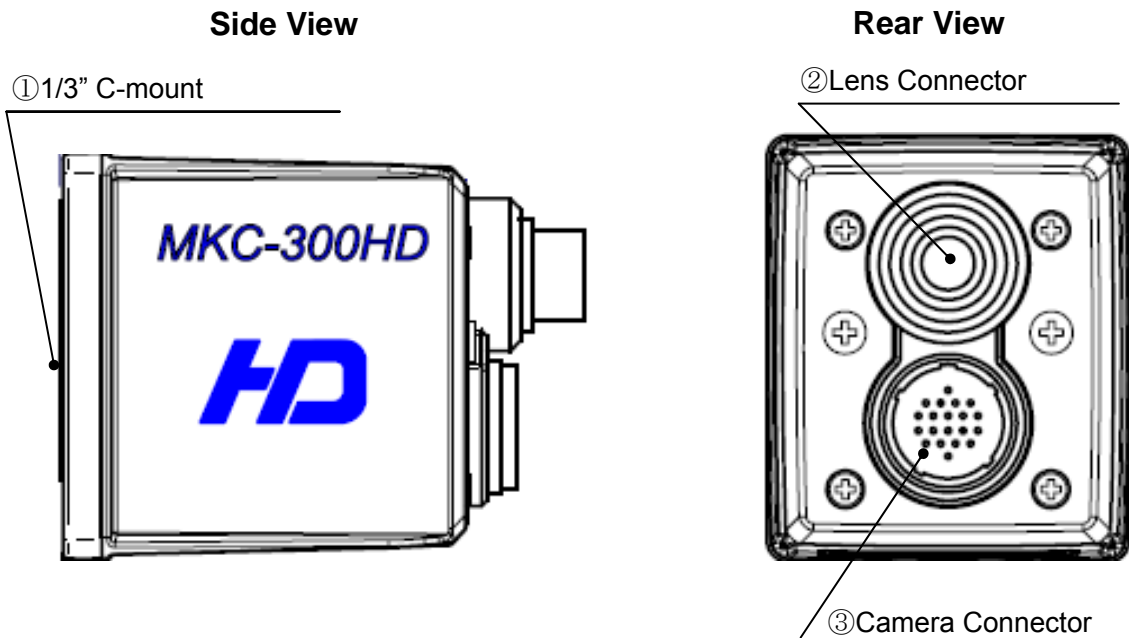

① 1/3" C-mount

Mount for connecting the lens and microscope adapter.

② Lens Connector

Used to connect the Iris cable of the special microscope adapter and 1/3" C-mount lens.

Lens Connector Pin Assignment (Connector Type: HR10A-7R-4S)	
1	+12V
2	GND
3	IRIS
4	N.C

③ Camera Connector

Used to connect to the Camera connector of CCU with the Camera cable.

■ Front Panel of Camera Control Unit (CCU)

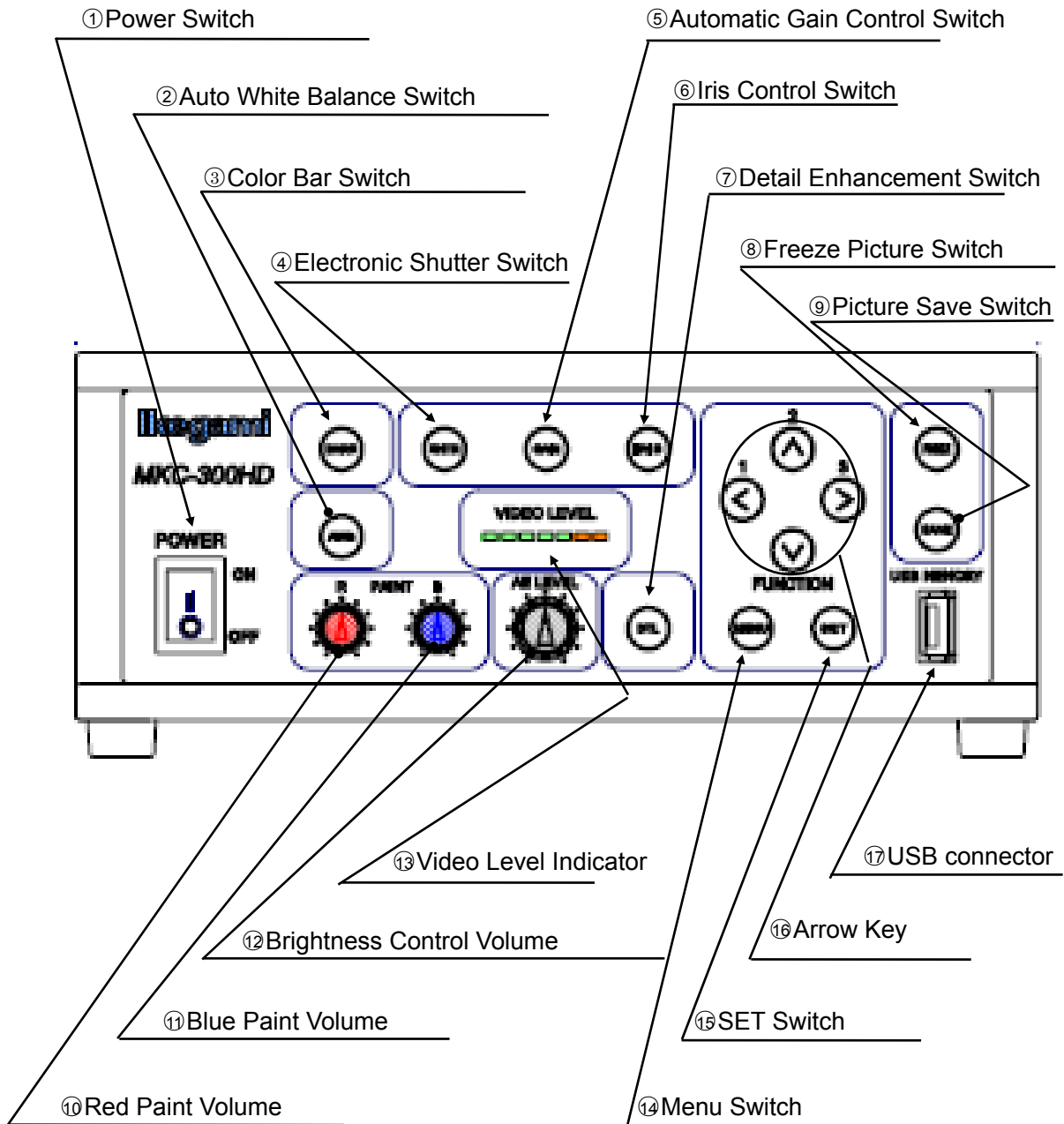

① Power Switch

To power on/off MKC-300HD. When this switch is turned on, the logo of "Ikegami" lights up blue. Pressing the top of the switch turns on power, and pressing the bottom of the switch turns off power. When this switch is turned on, the picture is output in the state where power was last turned off. However, the state of still screen picture is not

held.

② Auto White Balance Switch

To execute Auto White Balance. Use this switch, when the camera is not used for a certain time, color balance is not proper, and the light source changes. To control the white balance, project a white photographic object and adjust the iris just before LEVEL INDICATOR lights up red. When AWB switch is pressed, "Auto White Balance" appears on the monitoring screen to execute auto white balance. After several seconds, "= OK =" appears on the screen, ending auto white balance.

When an auto iris lens or an iris control adjustable microscope adapter is used, the iris will be set to an optimum condition automatically.

③ Color Bar Switch

Output an internal color bar signal of the camera to a color monitor. This color bar signal can be used to control the brightness, contrast, etc. of the color monitor.

④ Electronic Shutter Switch

To keeps the video signal output level constant by controlling shutter speed automatically. Automatic switching from 1/100 seconds to 1/10,000 seconds. When this switch is used with ⑤Automatic Gain Control Switch, an optimum picture can be output regardless of the brightness of an object.

⑤ Automatic Gain Control Switch

When shooting a dark scene from a bright scene, this function automatically controls sensitivity setting inside the camera, thereby keeping the video signal output level constant. It is possible to choose between increasing sensitivity by 6steps from up to +3dB (1.5 times) and till up to +18dB (6 times) on the menu. When this switch is used with ④Electronic Shutter Switch, an optimum picture can be output regardless of the brightness of a photographic object.

⑥ Iris Control Switch

To switch the iris of the microscope adapter and lens to Auto (Auto iris).

⑦ Detail Enhancement Switch

The skin tone color is mainly enhanced.

⑧ Freeze Picture Switch

By pressing the switch, the video images can be captured as a still picture.

⑨ Picture Save Switch

Press the switch to acquire the still picture from the camera into USB storage connected to 17USB connector. The picture quality is 1920x1080 pixels at Bitmap format (non-compressed) or 1920x1080 pixels at JPEG format. The stored picture quality can be adjusted on the menu.

⑩ Red Paint Volume

To finely control the red color on the video images.

⑪ Blue Paint Volume

To finely control the blue color on the video images

⑫ Brightness Control Volume

To finely control the brightness of the video images. It works as a control function while ④Electronic Shutter and ⑤Automatic Gain Control are operative. When using an auto iris adjustable microscope adapter or an auto iris lens, it works as a fine control function, with ⑥Iris Control Switch turned on. It can be manually controlled when this switch turned off.

⑬ Video Level Indicator

Indicate the video output level. When LED of the video level indicator lights up red, it means that the video output signal level has exceeded 100%.

⑭ Menu Switch

To display the menu that the user can set as desired on the monitor.





Select an item you want to set with ⑯Arrow key and define it with ⑭Menu Switch for menu items you can set.

Refer to "Menu Operation" (Page 15) for further detailed operations.

⑮ SET Switch

To define the item you want to set with the menu displayed, press this switch. Refer to "Menu Operation" (Page 15) for further detailed operations.

⑩ Arrow Key

To select a scene file among 1, 2, 3 and Function. The scene file setting can be fixed through the menu. When selecting an item you want to set on the menu, move cursor by clicking Arrow Keys  , and changing the contents of the item you want to set, choose the value you have set by clicking Arrow Keys  .

⑪ USB Connector

Used to connect the USB storage for saving a still picture.

■ Rear Panel of Camera Control Unit (CCU)

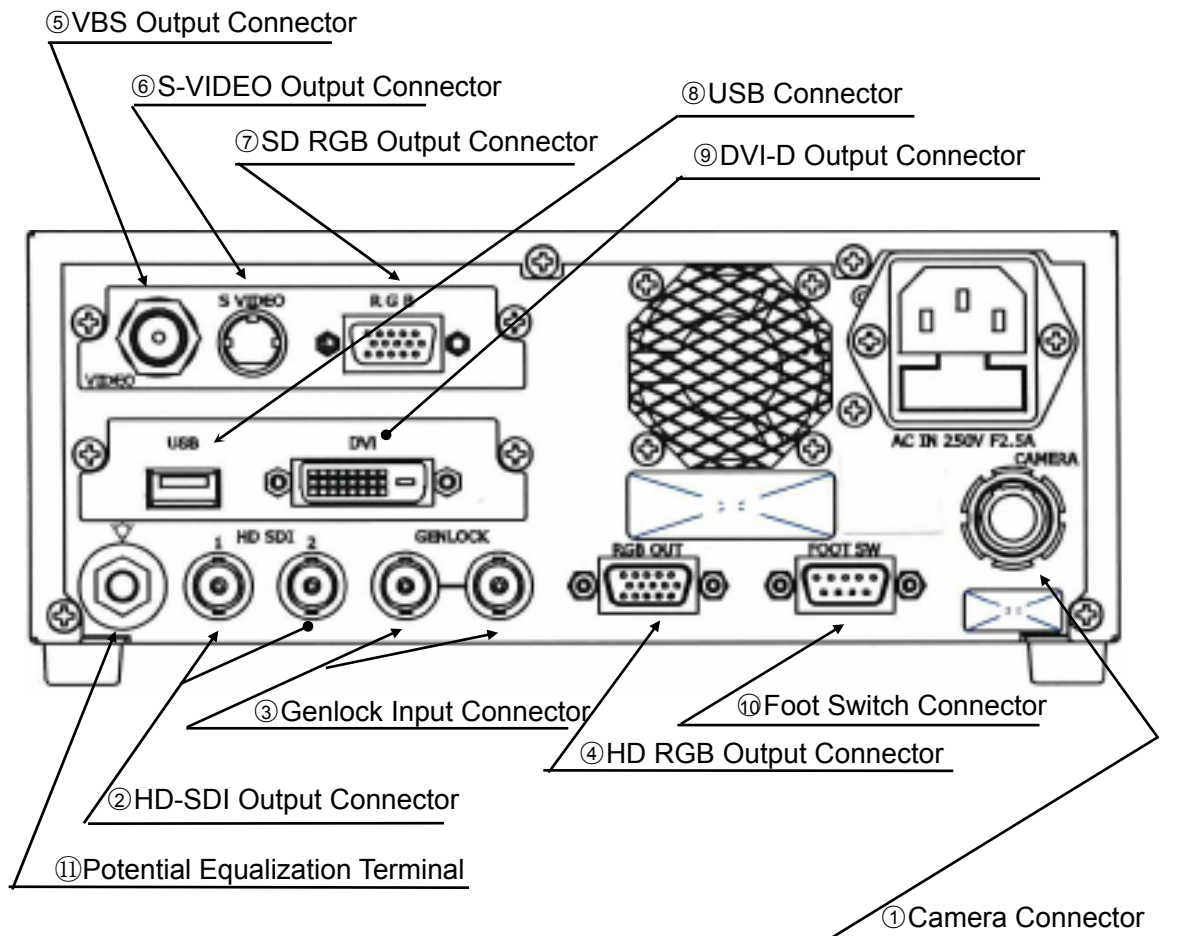

① Camera Connector

Connect the camera cable from the camera head.

② HD-SDI Output Connector

Output 2ch of HD-SDI signal.

Connect a Video Cable (Option) to a HD-SDI input interfaced monitor.

③ Genlock Input Connector

To use in phase synchronization with other systems. Connect a synchronized signal from another system. Equivalent to Three-Phase Synchronization (HD) and Two-Phase Synchronization (SD).

④ HD RGB Output Connector

Output HD RGB video signal. YPbPr video signal output is also available by changing the setting on the menu.

Refer to “Video Setting” (Page 19) for further detailed operations.

Connect a RGB Video Cable (Option) to a RGB input interfaced monitor.

⑤ VBS Output Connector (SD)

Output SD video signal.

Connect a Video Cable (Option) to a SD Video input interfaced monitor.

⑥ S-VIDEO Output Connector (SD)

Output Y/C video signal.

Connect a S-VIDEO Cable (Option) to a S-VIDEO input interfaced monitor.

⑦ SD RGB Output Connector

Output SD RGB video signal. YPbPr video signal output is also available by changing the setting on the menu.

Refer to “Video Setting” (Page 19) for further detailed operations.

Connect a RGB Video Cable (Option) to a RGB input interfaced monitor.

⑧ USB Connector

Connect USB storage device.

⑨ DVI-D Output Connector

Connect a DVI-D Cable (Option) to a DVI-D input interfaced devices such as monitor.

⑩ Foot Switch Connector

To connect the FOOT SW cable extension from the foot switch (black) for a still picture capturing.

⑪ Potential Equalization Terminal

This connector uses for potential equalization grounding which have one point of protective earth.

3. Operation

■ Connection

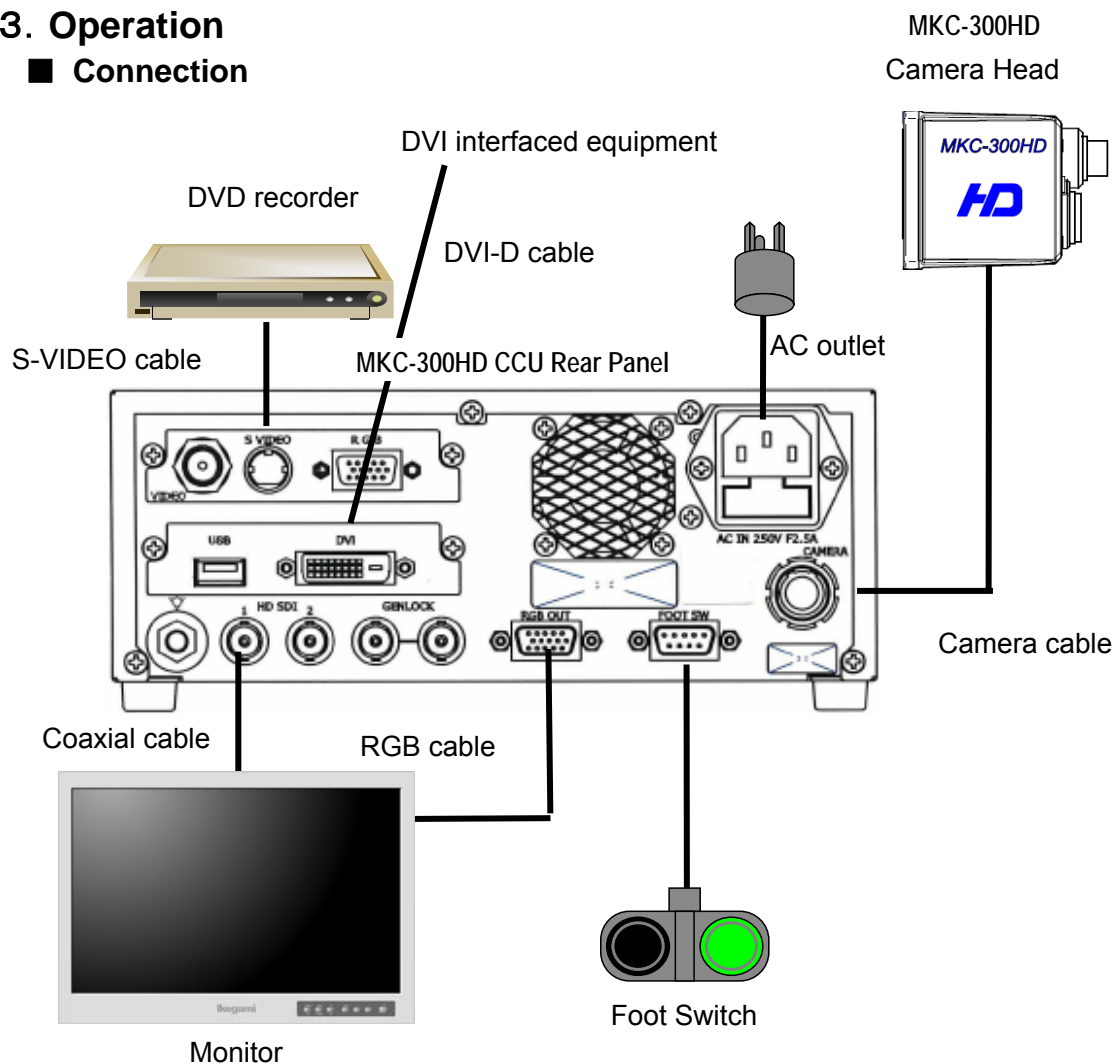

* Terminate the output from RGB OUT and VIDEO OUT at 75ohms on the receiver side.

CAUTION for USB Connection

The USB output of this camera is provided to record picture signals at JPEG or BMP format only into an external USB storage device, and it has no function to exchange the control signal from external equipment.

When making USB connection between this camera and a USB storage device, the USB output may not operate properly according to equipment.

For USB storage device of which operation has been already confirmed, please contact our company.

■ Electrical Connection

Turn on power supply to the monitor and other external equipment. Check that CCU and the camera head are connected with a camera cable, and then turn on power supply (POWER switch) of CCU.

When power to CCU is turned on, MKC-300HD(CAMERA HEAD+CCU) is initialized by the built-in computer. The pictures on the monitor are not stable during this period. However it is not a failure.

When initialization is finished, the video image from the camera is output under the same setting condition with the last use. (Note1)

- * When moving the CCU, be sure to turn off the POWER switch, disconnect the power plug and remove the connecting cable between equipment beforehand.

CAUTION



Caution for Camera cable connection and disconnection

Turn off the power of MKC-300HD when you connect or disconnect the camera cable. If the CCU is turned on, it may cause the fault of MKC-300HD.

NOTE: Phenomenon on video image

MKC-300HD may happen following phenomenon on its video image. It is not failure but it is because of employing CMOS sensor

When its sensitivity gain is going up and/or when it is slow shutter mode, it may appear high lighting dots. In case under high temperature condition, it may be remarkable.

It may appear horizontal stripe pattern or flicker on a video image under the fluorescent lighting. In this case, please use manual electrical shutter of 1/100 (50Hz area) or 1/120 (60Hz area). It will be reduce, but please note that it will not disappear at all.

In case of fast moving object on a video image, it may appear distortions.

Note1

When power is turned off in the state of still screen picture, that state will not be held even if power is turned on again, and MKC-300HD is set to the normal shooting state.

■ Setting Auto White Balance

Usually, MKC-300HD can be operated immediately after turning the power switch on. Therefore, any other operations are unnecessary.

However, when using MKC-300HD for the first time, or when the light source has been changed, Auto White Balance setting is required.

<Operation>

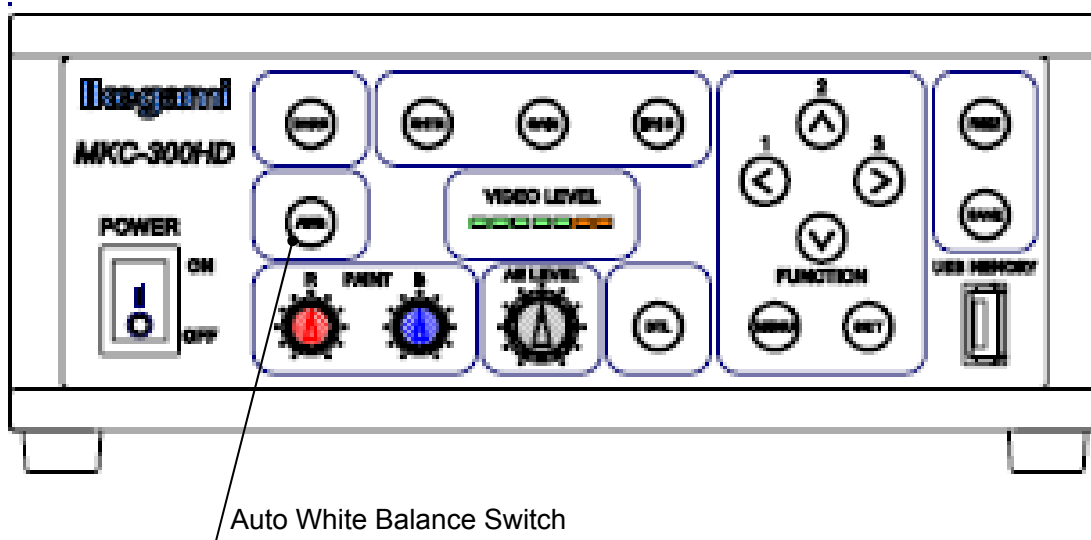

① Shoot a white photographic object on the screen largely. Set the picture level to such a degree that the white photographic object is not excessively bright, and press AWB button.

② “Auto White Balance” appears on the monitor screen. When auto white balance is finished, “OK” appears.

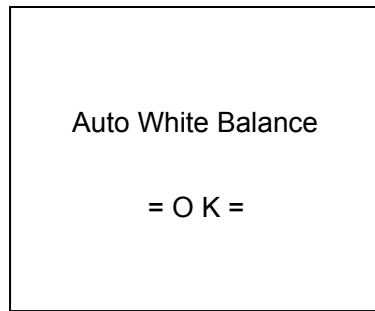
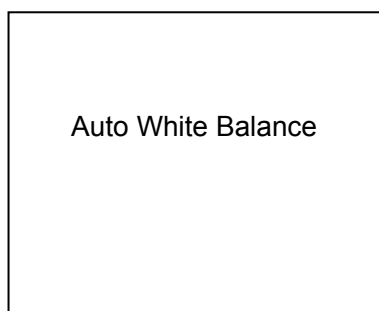

When the video level is low, "Too Dark" appears.

If Auto White Balance is "NG", check the video level etc. and then press the white balance switch again.



4. Menu Operation

MKC-300HD has various useful and practical functions. The user can select and set these functions on the menu. The basic operation is as follows.

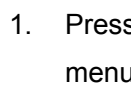
■ Operation Method

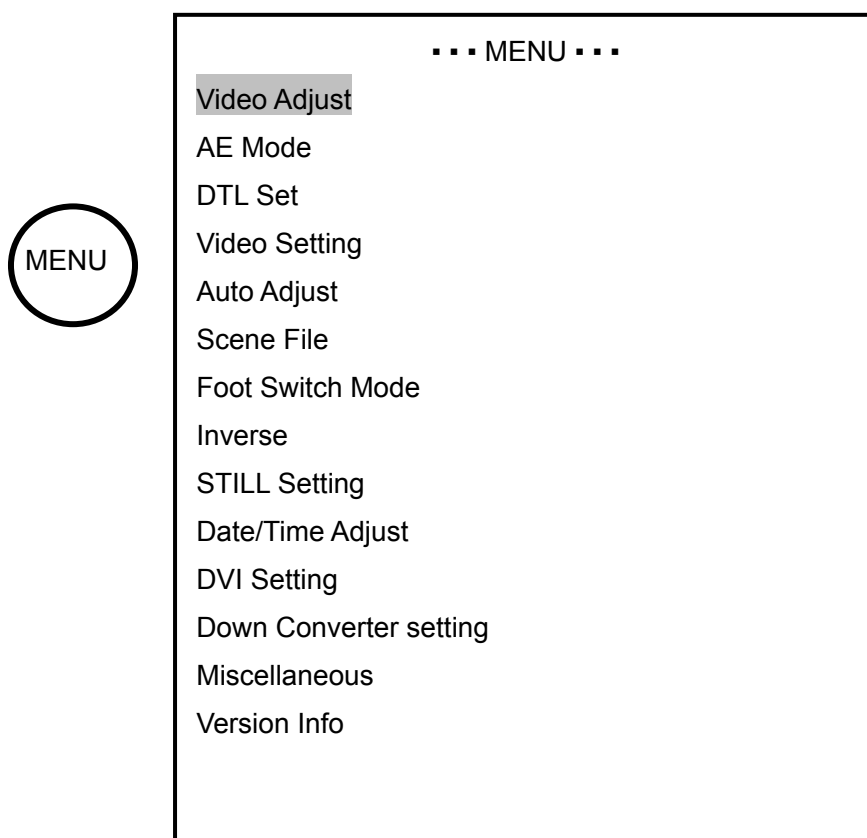
1. Pressing the  Menu switch (ref. page 5) on the front panel of CCU displays a menu on the monitoring screen, on which various camera functions can be set.



2. Select an item by Arrow Keys   on the front panel of CCU, and press SET switch to define the mode.

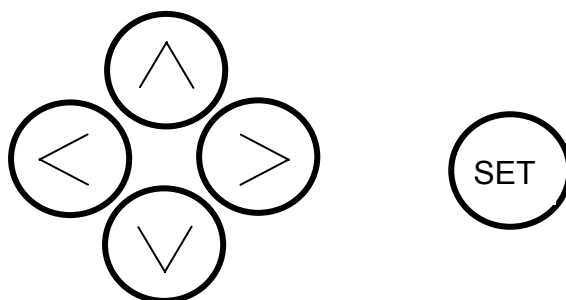

* Pressing Menu switch on the front panel of CCU while the menu screen is displayed quits the menu screen.

■ Video Adjust

Used to adjust the level of black, red and blue of video picture.

Video Adjust	
QUIT	
Master Pedestal	-5
Gain Offset Red	0
Blue	0

- [Master Pedestal] Used to change the master pedestal value by Arrow Keys ⏪ ⏩. It is not used during ordinary operation.
- [Gain Offset Red] Used to change the level of red by Arrow Keys ⏪ ⏩ switches. It has the same function as ⑩ Red video volume (ref. page5) on the front panel of CCU.
- [Blue] Used to change the level of blue by Arrow Keys ⏪ ⏩ switches. It has the same function as ⑪ Blue video volume on the front panel of CCU.

■ AE Mode

Used to adjust the electronic shutter and automatic sensitivity setting.

AE Mode	
QUIT	
Manual Shutter	OFF
AE Level Set	0
AE Speed	Middle
AE Sensitivity	40
Peak Ratio Set	0
Area Select	Middle
AGC Max Gain	3dB
Normal Gain setting	-3dB
Auto Shutter Limit	1/10000

- [Manual Shutter] Usually, turn it to OFF. When using at a certain electronic shutter speed, change it by Arrow Keys ⏪ ⏩ switches.
- [AE Level Set] Used to finely control brightness, when Manual Shutter is turned off, and either or both of ④ Electronic Shutter Switch (ref. page5) and ⑤ Automatic Gain Control Switch on the Front Panel of CCU are turned on. It has the same function as ⑫ Brightness Control Volume on the Front Panel of CCU.
- [AE Speed] Used to select the response rate of the Electronic Shutter and Automatic Gain Control from among Middle, Fast and Slow.
- [AE Sensitivity] To adjust the tolerance level ratio to the target level according to the peak value of video signal within the photometric area and the electronic shutter.
- [Peak Ratio Set] To change the type of photometry while the Electronic Shutter and Automatic Gain Control are operative. [+]direction: Peak value photometry. [-]direction: Average value photometry.

[Area Select]	Used to select a photometric area from among SP Narrow, Narrow, Middle, Wide and Full.
[AGC Max Gain]	To choose maximum Gain among +3dB, +6dB, +9dB, +12dB, +15dB and +18dB while Automatic Gain Control is operative.
[Normal Gain setting]	To select Gain level while Automatic Gain Control is not activate.
[Auto Shutter Limit]	To fix the maximum shutter speed while Automatic Gain Control is operative.

■ DTL Set

Used to adjust detail enhancement.

DTL Set	
QUIT	
DTL	ON
DTL Gain	10
Skin DTL Gain	25

[DTL]	Set it to ON usually. Used to turn on an off whole picture detail enhancement. When it is set to OFF, the detail enhancement switch on the Front Panel of CCU is not operative.
[DTL Gain]	To adjust the detail enhancement level.
[Skin DTL Gain]	To adjust the detail enhancement level when turning on ⑦ Detail Enhancement Switch (ref. page5) on the Front Panel of CCU.

■ Video Setting

To select display method for the still picture.

Video Setting	
QUIT	
Format	1080i/59.94
Aspect	16:9
Analog Output	YPbPr

- [Format] Select the video signal format among 1080i/59.94, 1080i/50, 720P/59.94 and 720P/50.
- [Aspect] Select Picture Aspect ratio from 16:9 and 4:3.
- [Analog output] Select the picture format for analogue video output from RGB and YPbPr.

■ Auto Adjust

Used for automatic black level control.

Auto Adjust	
QUIT	
Auto Black Balance.	Ready
Auto White Shade	Ready

[Auto Black Balance]

Used for Automatic Black Level control. If this adjustment is not performed with the lens are fully closed, it will adversely affect the picture output of the camera. No problem will occur, even if it is not used during ordinary operation.

[Auto White Shade]

Used for automatic white shading correction. Use it, when there is a large difference between brightness near the center and brightness in the neighboring part.

■ Scene File

Used to read and write a scene file, and also reset to the factory default.

Scene File		
QUIT		
Store Scene	1	Ready
Store Scene	2	Ready
Store Scene	3	Ready
Store Scene	4	Ready
Load Factory Default.		Ready
Auto Store		ON

- [Store Scene 1] When setting is changed, the data can be saved in Scene file 1.
- [Store Scene 2] When setting is changed, the data can be saved in Scene file 2.
- [Store Scene 3] When setting is changed, the data can be saved in Scene file 3.
- [Store Scene 4] When setting is changed, the data can be saved in Scene file 4.
- [Load Factory Default] Used to read the factory default data. Used to cancel the changed setting. To execute, select Start and the press SET switch.
- [Auto Store] When setting is changed, this function is used to set whether or not the data is saved at the scene file that has been automatically selected at the time. In case of OFF, the changed setting can be stored by [Store Scene 1] - [Store Scene4] procedure above mentioned.

■ Foot Switch Mode

Used to select the operation of the foot switch to be connected.

Foot Switch Mode	
QUIT	
Foot Switch 1	Save
Foot Switch 2	Scene File
Foot Switch 3	Freeze
Foot Switch 4	Freeze

- [Foot Switch 1] Select a function of the black foot switch from among Screen control (Freeze), Save (Still picture store), Scene File, Fluorescein, Frip, Mirorr and Rotate.
- [Foot Switch 2] Select a function of the green foot switch from among Screen control (Freeze), Save (Still picture store), Scene File, Fluorescein, Frip, Mirorr and Rotate.
- [Foot Switch 3] Select a function of the third foot switch from among Screen control (Freeze), Save (Still picture store), Scene File, Fluorescein, Frip, Mirorr and Rotate.
- [Foot Switch 4] Select a function of the fourth foot switch from among Screen control (Freeze), Save (Still picture store), Scene File, Fluorescein, Frip, Mirorr and Rotate.

■ Inverse

To select the video image inverse (Top and Down, Right and Left).

Inverse	
QUIT	
Horizontal	OFF
Vertical	OFF

[Horizontal]

Select ON to inverse the video image Right to Left.

[Vertical]

Select ON to inverse the video image Bottom to Top.

■ STILL Setting

Used to set the quality of a still picture to be stored in an external device (USB memory)

STILL Setting	
QUIT	
Format	JPEG
JPEG Factor	4

[Format]

To determine the format of the still picture. Select JPEG format or Bitmap format.

[JPEG Factor]

To determine the compression rate of JPEG format. Higher number means increasing compression rate and the file size becomes smaller.

■ Date/Time Adjust

To set Date and Time.

Date/Time Adjust	
QUIT	
Year	2009
Mouth	1
Day	15
Hour	13
Minute	00
Adjust	Ready

When Date and Time have been changed, move to “Adjust” and select “Start” before quit the menu.

■ DVI Setting

To set DVI output signal format.

DVI Setting	
QUIT	
Format	1080I

[Format]

To set DVI output signal format from 1080P and 1080I.

■ Down Converter setting

To set analogue video signal mode of Down Converter output.

Down Converter setting	
QUIT	
Format	Side Cut
Analog Output	RGB

[Format] To set analogue video format from among Side Cut size, Letter Box size and Squeeze size.

[Analog Output] To set analogue video format from RGB format and YCbCr.

■ Miscellaneous

Used for other settings.

Miscellaneous	
QUIT	
Initialize (ex.Scene)	Ready
Media Format	Ready
Cable Length	15m
Bar Mode	Multi
Center Marker	OFF

[Initialize (ex.Scene)] To read the factory default data expect for Scene file setting data.

[Media Format] To execute initial format USB storage device

[Cable Length] To select the camera cable length.

[Bar Mode] To display Color Bar signal on the monitor.

[Centre Marker] To display a marker to adjust a centre point.

■ Version Info

To display the software version of this camera.

Version Info			
QUIT			
ROM	:	*. *. *	
FPGA1	:	*. *. *	
FPGA2	:	*. *. *	
FPGA3	:	*. *. *	
CPLD1	:	*. *. *	
HEAD	:	*. *. *	
PANEL	:	*. *. *	

5. Specification

■ Ratings

Optics	RGB Prism method		
Sensor Scanning System	1125 / 59.94Hz Progressive Scan		
Image Pickup Device	1/3-inch 2,07M pixels CMOS x 3		
Effective Pixels	1920(H)× 1080(V)		
Lens Mount	C-Mount		
Video Output	2:1 Interlace 1125 Line/59.94 Field, 30 Frame		
Aspect Ratio	H16:V9		
Output Video Signal	HDTV Output		
	Analog Y, Pb, Pr	D-sub	1 Line
	HD-SDI	BNC	2 Lines
	DVI(1920x1080i/p)		1 Line
	SDTV Output (Down Convert)		
	Composite(VBS)	BNC	1 Line
		D-sub	1 Line
	S-VIDEO	S-Terminal	1 Line
		D-Sub	1 Line
	RGB	D-sub	1 Line
Input Video Signal	External Sync	Tri-Sync: 0.6Vp-p / 75 ohms or BBS: 0.3Vp-p / 75 ohms	

Input Video Signal	Remote Input	4contact [D-Sub 9-pin Female] 1 Line (Select from Still Image, Capture, Scene File and Image Flip & Turn)
Interface	USB2.0 (Still Image Capture)	2 Lines
Electrical Shutter Speed	1/60 to 1/10000 (Rolling Shutter)	
Camera Cable Length	5m+10m (Basic Cable Length/Option) Max.20m (Using Standard Cable Extension/Option) Max.30m (Using Custom Cables and others/Option)	
Power Requirement	AC100V to 240V±10%	
Power Consumption	100VA	
Operating Temperature	0°C to 40 °C	
Storage Temperature	-10°C to 60°C	
Dimensions/Weight	Camera Head: W34xH40xD40mm (without protrusion) 100g or less CCU: W210xH80xD300mm (without protrusion) 2.5kg or less	
Accessories	AC Power Cable (10A/125V : KP320/KS31 SJT—3 10A/250V : KP4819D/KS31A GTCE-3) , USB memory	

■ Performance

Resolutions	Horizontal 1000TV Lines
S/N Ratio	54dB (γ and Detail Off, Encoder output)
Sensitivity	Standard 2000lux F10/3200K
Registration Error	Full Screen within 0.05%

■ Functions

Image Flip and Turn
Still Image Capture
Scene File
Down Convert (SDTV Output)

Auto Function	Auto White Balance Auto Gain Control Auto Shutter Iris Auto Iris Control Auto White Shading
Detail Enhancement	Skin Tone Detail On/Off (Skin Tone Detail Enhancement)
Slow Shutter	Up to 1/4 seconds slow shutter speed available
Paint	R-channel / B-channel (Level Adjustable)
AE Level	Exposure Level Adjustable
Video Level Indicator	7 steps
Color Bar	Built-in
Photometry Area	Selectable in Menu
4:3 Video Output	4:3 Side Cut
Still Image Capture	1920x1080 dots still picture on a USB memory JPEG or BMP selectable
Others	Various set up from On Screen Menu

6. External Appearance

■ Camera Head

Unit: mm

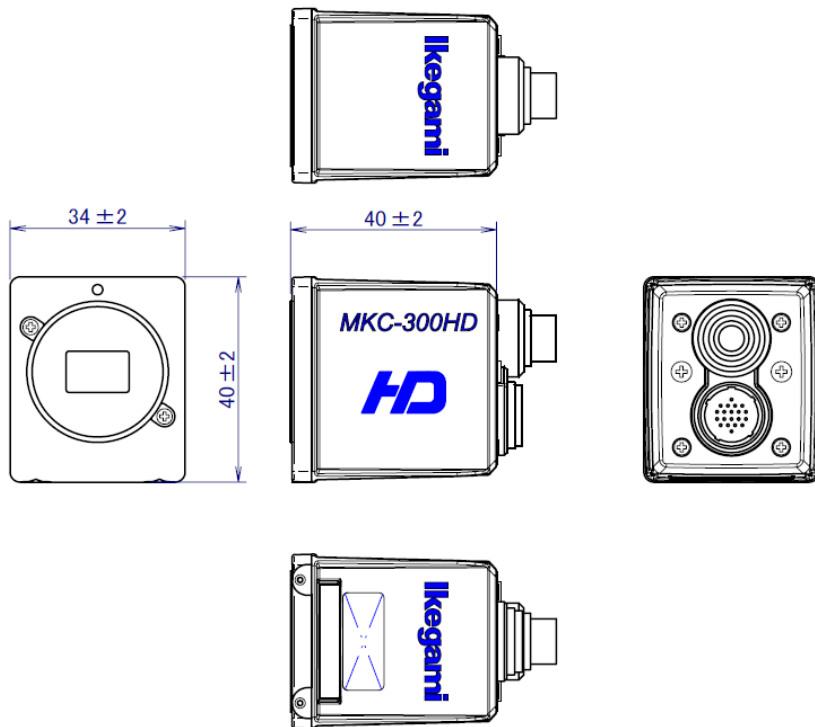

■ CCU

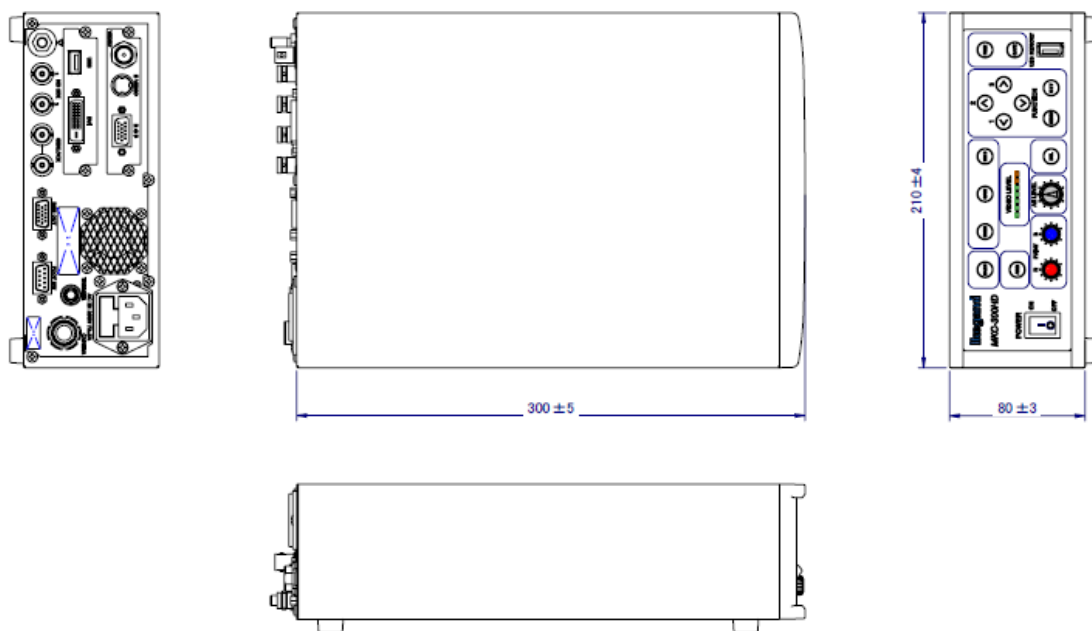

MKC-300HD

Digital Processing Compact 3CMOS Color Camera
Operation Manual

First Issue March 2010

Published by Ikegami Tsushinki Co., Ltd.

- It forbids to copy it without notice and to reproduce it about a part of this manual or all as for any method as well without taking the assent of Ikegami Tsushinki Co., Ltd.
- A specification and an appearance are sometimes changed without notice.

Edited by Chuo seizu Co., Ltd.

Ikegami

Ikegami Tsushinki Co., Ltd.

5-6-16, Ikegami, Ohta-ku, Tokyo, 146 Japan

Phone: 03-5700-1111, Fax: 03-5700-1137

■ **Ikegami Electronics (U.S.A.), Inc.**

37 Brook Avenue, Maywood, New Jersey 07607, U.S.A.

Phone: (201)368-9171, Fax: (201)569-1626

■ **Ikegami Electronics (Europe) GmbH**

Ikegami strasse 1, 41460 Neuss 1, F.R Germany

Phone: (02131)123-0, Fax: 02131)102820